



Customer First!
STARION is here to serve customers.

A product just for you to make you even more special!
 STARION Technology with 5 Decades of History!
 It will make you even more special.



STARION www.starion.co.kr
 STARION Service Center

The information within this catalogue is prepared to help customers better understand the features of the products. The contents are subject to change depending on the future market trends and release dates; thus, it is strongly advised to verify the product information through product manuals and with salespersons at stores when purchasing the product. The colors of the products in this catalogue may vary from the actual products due to technicalities during the printing process. All unauthorized use of any information within this catalogue is subject to civil and criminal offenses pursuant to the Copyright Act. Any unauthorized reproductions and duplications are strictly prohibited. Quality Satisfaction Awards and Good Design Award are based on Korea standards

November, 2016



Shining Star at Commercial Kitchen

STARION

Ho-Jin Kim, Korean famous Actor
 Spokesperson for STARION



STARION

Preserve Freshness from the Farm to the Kitchen!

Guaranteed by STARION technology accumulated for over 50 years Technology with 5 Decades of History.



67% 1 year-long electricity bill at a mere approx. USD 109.52
67% more savings on the electricity bill compared to equivalent models from competitors (Based on SR-S45A* model, measurements from the test conducted by the company with ISO502 Standards)

User-friendly drainage structure
All watery fluid is designed to be gathered at the front because the rear-side surface is 1 degree higher than the front-side surface in addition to separate waterways. This feature allows easy drainage and cleaning without having to remove food materials from the refrigerator.

Design of Inner Materials with Stainless Steel
High-end stainless steel materials ensure convenient cleaning and easy maintenance.

Height-adjustable Shelves
With height-adjustable shelves, the space inside the refrigerator can be fully utilized depending on the size and volume of food materials to store.

More Spacious Storage Space without Bottle Rails
By removing the rails for bottles, it offers more space to store food materials.

43dB Low-noise Design
Don't worry. The refrigerator is properly working right now. (Based on SR-S25D* model)

High-density polyurethane foam
The thickness of polyurethane foam varies at each section based on the researches upon optimal thickness of polyurethane foam in order to minimize heat loss and secure maximum storage space.

Instant Freezing
The feature runs freezing operation for 2 hours and automatically shuts off by simply pressing a button. It assures easy and prompt cold storage of food materials.

Easy-to-use Temperature Control Unit
With a special sensor, temperature can be easily controlled in addition to convenience of temperature verification, and it also preserves the freshness of food materials at optimal condition for long durations.

No silicon, no fungus!
No need to worry about fungus since STARION commercial refrigerator is completely free of silicon.

Automatic Door-Shut within 45 degrees
Automatic door-shut feature ensures the door to be closed within 45 degrees, which is a must-have feature for commercial kitchens.

Frost Removal Feature
This feature removes frost which is generated every time the door opens and shuts. It enhances preservation and usability of food materials.

Application of LG Compressor with Powerful Freezing Capability
Armed with a powerful LG Compressor, it provides ever-powerful refrigeration and freezing functions.

STARION | Commercial Refrigerator

STARION 1100ℓ/38.8 cu.ft. 45Box-Metal

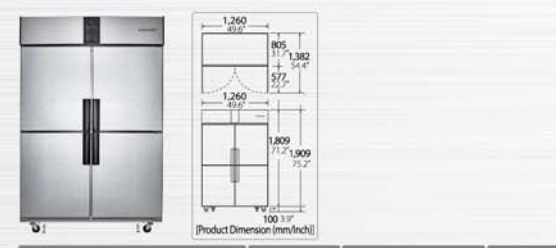

STARION 1100ℓ/38.8 cu.ft. 45Box-Stainless Steel

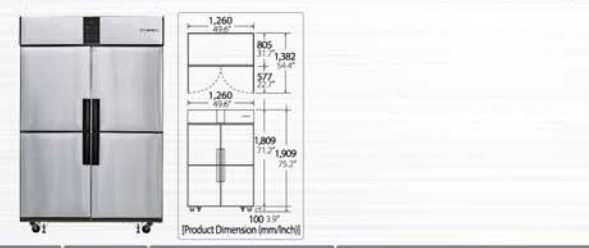

Type	Model	Material		Dimension (WxDxH)mm/Inch	Weight (kg/lb)	Capacity(ℓ/cu.ft.)			Temperature Range		Power Consumption (kWh/M)
		External	Internal			Freezer Chamber	Refrigeration Chamber	Total	Freezer Chamber	Refrigeration Chamber	
1100ℓ / 38.8 cu.ft. 1/4 Freezer	SR-S45A**	Metal	STS	1,260x805x1,909	157	240	830	1,070	6-level Temperature Control (-11°F ~ 41°F)	6-level Temperature Control (23°F ~ 44.6°F)	63.0
	SR-S45AS**	STS	STS	49.6"x31.7"x75.2"	153	8.5	29.3	37.8	(-24°C ~ 5°C)	(-5°C ~ 7°C)	
1100ℓ / 38.8 cu.ft. 1/2 Freezer (Vertical)	SR-S45B**	Metal	STS	1,260x805x1,909	147	530	530	1,060	6-level Temperature Control (-11°F ~ 41°F)	6-level Temperature Control (23°F ~ 44.6°F)	80.0
	SR-S45BS**	STS	STS	49.6"x31.7"x75.2"	145	18.7	18.7	37.4	(-24°C ~ 5°C)	(-5°C ~ 7°C)	
1100ℓ / 38.8 cu.ft. 1/2 Freezer (Horizontal)	SR-S45C**	Metal	STS	1,260x805x1,909	145	532	541	1,073	6-level Temperature Control (-11°F ~ 41°F)	6-level Temperature Control (23°F ~ 44.6°F)	86.0
	SR-S45CS**	STS	STS	49.6"x31.7"x75.2"	141	18.8	19.1	37.9	(-24°C ~ 5°C)	(-5°C ~ 7°C)	
1100ℓ / 38.8 cu.ft. All Freezer	SR-S45D**	Metal	STS	1,260x805x1,909	140	1,110	—	1,110	6-level Temperature Control (-11°F ~ 41°F)	—	N/A
	SR-S45DS**	STS	STS	49.6"x31.7"x75.2"	138	39.2	—	39.2	(-24°C ~ 5°C)	—	
1100ℓ / 38.8 cu.ft. All Refrigeration	SR-S45E**	Metal	STS	1,260x805x1,909	124	—	1,110	1,110	—	6-level Temperature Control (23°F ~ 44.6°F)	35.0
	SR-S45ES**	STS	STS	49.6"x31.7"x75.2"	120	39.2	39.2	—	(-5°C ~ 7°C)	—	

* STS = Stainless Steel / Power Consumption = Korean Standards

STARION 1700ℓ/60 cu.ft. 65Box



“ Easy-to-assemble Refrigerator
TWO refrigerators can become One massive refrigerator! ”

Type	Model	Material		Dimension (WxDxH)mm/Inch	Weight (kg/lb)	Capacity(ℓ/cu.ft.)			Temperature Range		Power Consumption (kWh/M)
		External	Internal			Freezer Chamber	Refrigeration Chamber	Total	Freezer Chamber	Refrigeration Chamber	
1700ℓ / 60 cu.ft. 1/3 Freezer	SR-S65B**	Metal	STS	1,900x805x1,909	212	500	1,110	1,610	6-level Temperature Control (-11°F ~ 41°F)	6-level Temperature Control (23°F ~ 44.6°F)	98.0
	SR-S65BS**	STS	STS	74.8"x31.7"x75.2"	204	17.7	39.2	56.9	(-24°C ~ 5°C)	(-5°C ~ 7°C)	
1700ℓ / 60 cu.ft. All Freezer	SR-S65D**	Metal	STS	1,900x805x1,909	228	1,610	—	1,610	6-level Temperature Control (-11°F ~ 41°F)	—	N/A
	SR-S65DS**	STS	STS	74.8"x31.7"x75.2"	222	56.9	—	56.9	(-24°C ~ 5°C)	—	
1700ℓ / 60 cu.ft. Refrigeration	SR-S65E**	Metal	STS	1,900x805x1,909	210	—	1,610	1,610	—	6-level Temperature Control (23°F ~ 44.6°F)	49.0
	SR-S65ES**	STS	STS	74.8"x31.7"x75.2"	204	56.9	56.9	—	(-5°C ~ 7°C)	—	

* STS = Stainless Steel / Power Consumption = Korean Standards

STARION 500ℓ/17.7 cu.ft. 25Box

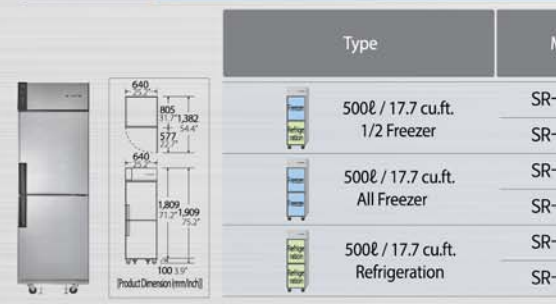

Type	Model	Material		Dimension (WxDxH)mm/Inch	Weight (kg/lb)	Capacity(ℓ/cu.ft.)		
		External	Internal			Freezer Chamber	Refrigeration Chamber	Total
500ℓ / 17.7 cu.ft. 1/2 Freezer	SR-S25A**	Metal	STS	640x805x1,909	85/187	244	240	484
	SR-S25AS**	STS	STS	25.2"x31.7"x75.2"	83/183	8.6	8.5	17.1
500ℓ / 17.7 cu.ft. All Freezer	SR-S25D**	Metal	STS	640x805x1,909	83/183	500	—	500
	SR-S25DS**	STS	STS	25.2"x31.7"x75.2"	79/174	17.7	—	17.7
500ℓ / 17.7 cu.ft. Refrigeration	SR-S25E**	Metal	STS	640x805x1,909	81/179	—	500	500
	SR-S25ES**	STS	STS	25.2"x31.7"x75.2"	79/174	—	17.7	17.7

* STS = Stainless Steel

STARION | Table Refrigerator



STARION W900 / 35.4" Table Refrigerator



Type	Model	Material		Dimension (WxDxH)mm/Inch	Weight (kg/lb)	Capacity(ℓ/cu.ft.)			Temperature Range Refrigeration Chamber	Remark
		External	Internal			Upper Storage	Inner Storage Space	Total		
Refrigeration W900 / 35.4" Table	SR-T09EIE**	Metal	STS	900X700X850 35.4"x27.6"x33.5"	54 119	-	-	-	Control by a single unit (23°F ~ 50°F) (-5°C ~ 10°C)	Left-side Grip Right-side Grip Left-side Grip Right-side Grip
	SR-T09EIF**									
	SR-T09ESE**									
	SR-T09ESF**									
Refrigeration W1000 / 39.4" Table (Customized)	SR-T10EIE**	Metal	STS	1,000X700X850 39.4"x27.6"x33.5"	56 123	-	167 5.9	167 5.9	Control by a single unit (23°F ~ 50°F) (-5°C ~ 10°C)	Left-side Grip Right-side Grip Left-side Grip Right-side Grip
	SR-T10EIF**									
	SR-T10ESE**									
	SR-T10ESF**									

STARION W1000 / 39.4" Table Refrigerator



STARION W1300 / 51.2" Table Refrigerator



Type	Model	Material		Dimension (WxDxH)mm/Inch	Weight (kg/lb)	Capacity(ℓ/cu.ft.)			Temperature Range Refrigeration Chamber	Remark	
		External	Internal			Upper Storage	Inner Storage Space	Total			
Refrigeration W1300 / 51.2" Table (Customized)	SR-T13EIE	Metal	STS	1,300X700X850 51.2"x27.6"x33.5"	67 148	-	-	266 9.4	266 9.4	Control by a single unit (23°F ~ 50°F) (-5°C ~ 10°C)	Left-side Grip Right-side Grip Left-side Grip Right-side Grip
	SR-T13EIF										
	SR-T13ESE										
	SR-T13ESF										

STARION W1500 / 59.1" Table Refrigerator, Freezer/Refrigerator



Type	Model	Material		Dimension (WxDxH)mm/Inch	Weight (kg/lb)	Capacity(ℓ/cu.ft.)			Temperature Range		Remark										
		External	Internal			Freezer Chamber	Refrigeration Chamber	Total	Freezer Chamber	Refrigeration Chamber											
Refrigeration / Refrigeration W1500 / 59.1" Table	SR-T15EIE	Metal	STS	1,500X700X850 59.1"x27.6"x33.5"	74 / 163 71 / 157	-	-	366 12.9	366 12.9	-	Control by a single unit (23°F ~ 50°F) (-5°C ~ 10°C)	Both doors open									
	SR-T15ESE																				
Freezer / Refrigeration W1500 / 59.1" Table (Freezer / Refrigeration)	SR-T15AIE	Metal	STS										1,500X700X850 59.1"x27.6"x33.5"	79 / 174 76 / 168	-	-	171.5 6.1	171.5 6.1	343 12.2	Control by a single unit (-13°F ~ 5°F) (-25°C ~ -15°C)	Both doors open
	SR-T15ASE																				
Freezer / Freezer W1500 / 59.1" Table (Freezer / Freezer)	SR-T15DIE	Metal	STS	1,500X700X850 59.1"x27.6"x33.5"	77 / 170 74 / 163	-	-	366 12.9	366 12.9	-	Control by a single unit (-13°F ~ 5°F) (-25°C ~ -15°C)	Both doors open									
	SR-T15DSE																				

STARION W1200 / 47.2" Table Refrigerator, Freezer

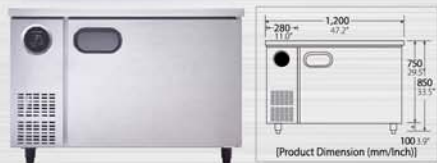

Type	Model	Material		Dimension (WxDxH)mm/Inch	Weight (kg/lb)	Capacity(ℓ/cu.ft.)			Temperature Range Refrigeration Chamber	Remark	
		External	Internal			Upper Storage	Inner Storage Space	Total			
Refrigeration W1200 / 47.2" Table	SR-T12EIE	Metal	STS	1,200X700X850 47.2"x27.6"x33.5"	65 143	-	-	266 9.4	266 9.4	Control by a single unit (23°F ~ 50°F) (-5°C ~ 10°C)	Left-side Grip Right-side Grip Left-side Grip Right-side Grip
	SR-T12EIF										
	SR-T12ESE										
	SR-T12ESF										
Freezer W1200 / 47.2" Table	SR-T12DIE	Metal	STS	1,200X700X850 47.2"x27.6"x33.5"	67 148	266 9.4	-	-	266 9.4	Control by a single unit (-13°F ~ 5°F) (-25°C ~ 15°C)	Left-side Grip Right-side Grip Left-side Grip Right-side Grip
	SR-T12DIF										
	SR-T12DSE										
	SR-T12DSF										

STARION W1800 / 70.9" Table Refrigerator, Freezer/Refrigerator



Type	Model	Material		Dimension (WxDxH)mm/Inch	Weight (kg/lb)	Capacity(ℓ/cu.ft.)			Temperature Range		Remark										
		External	Internal			Freezer Chamber	Refrigeration Chamber	Total	Freezer Chamber	Refrigeration Chamber											
Refrigeration / Refrigeration W1800 / 70.9" Table	SR-T18EIE	Metal	STS	1,800X700X850 70.9"x27.6"x33.5"	89 / 196 86 / 190	-	-	465 16.4	465 16.4	-	Control by a single unit (23°F ~ 50°F) (-5°C ~ 10°C)	Both doors open									
	SR-T18ESE																				
Freezer / Refrigeration W1800 / 70.9" Table (Freezer / Refrigeration)	SR-T18AIE	Metal	STS										1,800X700X850 70.9"x27.6"x33.5"	TBD	-	-	171.5 6.1	271.5 9.6	443 15.7	Control by a single unit (-13°F ~ 5°F) (-25°C ~ -15°C)	Both doors open
	SR-T18ASE																				

* STS = Stainless Steel

* STS = Stainless Steel

STARION | Side-dish Refrigerator



Frost Removal Feature
During frost removal, it allows water-cleaning through drainage. It maintains cleanliness 365 days a year along with clean storage.

Meticulous Temperature Control
With digital touch operation, it allows temperature control by a single degree.

Height-adjustable Shelves
With height-adjustable shelves, it ensures reasonable utilization of the space inside the refrigerator depending on the size and volume of food materials to store.

STARION W900 / 35.4" Side-dish Refrigerator



Type	Model	Material		Dimension (WxDxH)mm/Inch	Weight (kg/lb)	Capacity(ℓ/cu.ft.)			Temperature Range Refrigeration Chamber	Remark
		External	Internal			Upper Storage	Inner Storage Space	Total		
W900 / 35.4" Side-dish Refrigerator	SR-V09EIE**	Metal	STS	900X700X850 35.4"x27.6"x33.5"	54	62	131	193	Control by a single unit (23°F ~ 50°F) (-5°C ~ 10°C)	Left-side Grip
	SR-V09EIF**									Right-side Grip
	SR-V09ESE**	Left-side Grip								
	SR-V09ESF**	Right-side Grip								
W1000 / 39.4" Side-dish Refrigerator (Customized)	SR-V10EIE**	Metal	STS	1,000X700X850 39.4"x27.6"x33.5"	56	2.2	4.6	6.8	Control by a single unit (23°F ~ 50°F) (-5°C ~ 10°C)	Left-side Grip
	SR-V10EIF**									Right-side Grip
	SR-V10ESE**	Left-side Grip								
	SR-V10ESF**	Right-side Grip								

STARION W1,000 / 39.4" Side-dish Refrigerator



STARION W1300 / 51.2" Side-dish Refrigerator



Type	Model	Material		Dimension (WxDxH)mm/Inch	Weight (kg/lb)	Capacity(ℓ/cu.ft.)			Temperature Range Refrigeration Chamber	Remark
		External	Internal			Upper Storage	Inner Storage Space	Total		
W1300 / 51.2" Side-dish Refrigerator (Customized)	SR-V13EIE**	Metal	STS	1,300X700X850 51.2"x27.6"x33.5"	67	86	209	295	Control by a single unit (23°F ~ 50°F) (-5°C ~ 10°C)	Left-side Grip
	SR-V13EIF**									Right-side Grip
	SR-V13ESE**	Left-side Grip								
	SR-V13ESF**	Right-side Grip								

STARION W1500 / 59.1" Side-dish Refrigerator



Type	Model	Material		Dimension (WxDxH)mm/Inch	Weight (kg/lb)	Capacity(ℓ/cu.ft.)			Temperature Range Refrigeration Chamber	Remark		
		External	Internal			Upper Storage	Inner Storage Space	Total				
W1500 / 59.1" Side-dish Refrigerator	SR-V15EIE**	Metal	STS	1,500X700X850 59.1"x27.6"x33.5"	74 / 163	109	287	396	Control by a single unit (23°F ~ 50°F) (-5°C ~ 10°C)	Both doors open		
	SR-V15ESE**										71 / 157	3.8
W1500 / 59.1" 1/2 Side-dish Refrigerator	SR-V15EIEVB**	Metal	STS		1,500X700X850 59.1"x27.6"x33.5"	76 / 168	71	287		358	Control by a single unit (23°F ~ 50°F) (-5°C ~ 10°C)	Both doors open
	SR-V15ESEVB**											
W1500 / 59.1" 1/3 Side-dish Refrigerator	SR-V15EIEVA**	Metal	STS	1,500X700X850 59.1"x27.6"x33.5"		76 / 168	2.5	10.1	12.6	Control by a single unit (23°F ~ 50°F) (-5°C ~ 10°C)	Both doors open	
	SR-V15ESEVA**											73 / 161

STARION W1200 / 47.2" Side-dish Refrigerator



Type	Model	Material		Dimension (WxDxH)mm/Inch	Weight (kg/lb)	Capacity(ℓ/cu.ft.)			Temperature Range Refrigeration Chamber	Remark
		External	Internal			Upper Storage	Inner Storage Space	Total		
W1200 / 47.2" Side-dish Refrigerator	SR-V12EIE**	Metal	STS	1,200X700X850 47.2"x27.6"x33.5"	65	86	209	295	Control by a single unit (23°F ~ 50°F) (-5°C ~ 10°C)	Left-side Grip
	SR-V12EIF**									Right-side Grip
	SR-V12ESE**	Left-side Grip								
	SR-V12ESF**	Right-side Grip								
W1200 / 47.2" 1/2 Side-dish Refrigerator	SR-V12EIEVB**	Metal	STS	1,200X700X850 47.2"x27.6"x33.5"	67	55	209	264	Control by a single unit (23°F ~ 50°F) (-5°C ~ 10°C)	Left-side Grip
	SR-V12EIEVB**									Right-side Grip
	SR-V12EIEVA**	Left-side Grip								
	SR-V12EIEVA**	Right-side Grip								
W1200 / 47.2" 1/3 Side-dish Refrigerator	SR-V12EIEVA**	Metal	STS	1,200X700X850 47.2"x27.6"x33.5"	64	1.9	7.4	9.3	Control by a single unit (23°F ~ 50°F) (-5°C ~ 10°C)	Left-side Grip
	SR-V12EIEVA**									Right-side Grip

STARION W1800 / 70.9" Side-dish Refrigerator



Type	Model	Material		Dimension (WxDxH)mm/Inch	Weight (kg/lb)	Capacity(ℓ/cu.ft.)			Temperature Range Refrigeration Chamber	Remark
		External	Internal			Upper Storage	Inner Storage Space	Total		
W1800 / 70.9" Side-dish Refrigerator	SR-V18EIE**	Metal	STS	1,800X700X850 70.9"x27.6"x33.5"	89 / 196	132	365	497	Control by a single unit (23°F ~ 50°F) (-5°C ~ 10°C)	Both doors open
	SR-V18ESE**									

* STS = Stainless Steel

* STS = Stainless Steel

STARION | Dishwasher · Airo Cook



Simple Display, Easy-to-use Instructions

It enhances the user's convenience by minimizing operational buttons and indicating all processes through a display panel.

Powerful Washing through Jet Blast

Powerful cleaning pump dedicated to STARION models ensures thoroughly cleaning every inch of all dishes, cups and even bottles without leaving any stains through an optimized cleaning nozzle.

Temporary Suspension Feature & Self-diagnosis Function

With thermal fuse and preventive device for excessive rise, it ensures safety by immediately suspending the operation while displaying an ERROR message.

Rust-proof/Leakage-free Water Tank

Made and assembled with the same material (stainless steel), it is completely free from any leakage.

Adjustable Cleaning Capacity Based on Given Environment

It implements optimal cleaning condition through adjustability upon cleaning/rinse time as well as the volume of detergents and rinse agents.

Certifications (Korean Standards)

These products are certified for the safety and quality through acquisition of safety certificates/standard electromagnetic-wave certificates.

Cleaning Time

Standard Period: 70 seconds (Cleaning: 55 sec., Pause: 3 sec., Rinse: 12 sec.) The time for washing and rinse is adjustable subject to consumer's preference.

solenoid pump for detergents & rinse agent

By employing a solenoid pump for its superb durability and reactivity to detergents instead of a roll pump, it prevents mechanical failures since it uses proper volume of detergents.

Type	Model	Weight	Dimension (WxDxH)mm	Voltage	Max. Power Usage	Cleaning/Rinse				Cleaning Capacity (per hour)					
						Type	Tank Capacity	Cleaning/Rinse Time	Pump Capacity	Hot Water	Max. Temperature	Small & medium sized dishes	bowls	Large bowls	Cups
Dishwasher	SW-D500C	81 Kg / 176lb	With door closed 650x650x1,350 25.6"x25.6"x53.1"	220V~, 60Hz Single Phase	3.8 kW	Spraying type with upper/lower rotation	Cleaning 42 l / 1,522 oz	Cleaning: 35-95 seconds (set by a unit of 5 seconds) Rinse: 5-30 seconds (set by a unit of 1 second)	Cleaning: 1.1 kW Rinsing: 0.1 kW	X	Cleaning: 85°C / 185°F ± 10%	1,500	1,500	360	2,000
	SW-D500H	85 Kg / 187lb	With door open 650x650x1,800 25.6"x25.6"x70.9"		5 kW		Rinse 28 l / 947 oz					O	Cleaning - Rinsing: 85°C / 185°F ± 10%	(EA)	(EA)



STARION Electric Stove for healthy cooking
Shining & Stylish Kitchen



for healthy cooking with light and air
Airo Cook

GOOD DESIGN
Award by Korea Design Center

ECO

Eco-friendly

TPX material, eco-friendly new material, is used. Zero occurrence of endocrine disruptor

14.5L
Large capacity

Massive Capacity

Capable of cooking a large volume at once with massive 14.5L cooking space

Safety Device

Safety for cooking further enhanced through quintuplex safety device: Safety grip (ON/OFF) feature, mechanical overheating-prevention feature, power suppression unit through separation of body and bowl, motor overheating-prevention feature, PCB overheating-prevention feature.

Convenience

Latest technology of LED touch panel applied: Time adjustable by minutes/temperature adjustable by 5 degrees; Easy-and-convenient handling through TPX material.

Type	Model	Power Consumption	Dimension (WxDxH)mm/inch	Bowl Capacity	Rated Voltage	Weight	Safety Feature
Airo Cook	STO-1200	Halogen lamp/1,200W	375x360x375 14.8"x14.4"x14.8"	14.5L / 490 oz	220V / 60Hz	Approx. 5kg/11 lb	Quintuplex safety device

Shining & Stylish Kitchen

World-recognized SCHOTT Glass: Superb durability & thermal efficiency

German-made E.G.O heating element

3-5 seconds of heating velocity, suppression of nutrient destruction at 650°C-700°C

Dual Burner w/ Expanded Crater

More convenience accommodating containers in all sizes

Easy Cleaning

World-recognized SCHOTT Glass: Superb durability & thermal efficiency

Slice & Direct Touch

Easy-to-use through hand pressing and light touch

Smart Safety Features

Accident prevention through safety features such as child-proof lock, automatic power-off & automatic shut-down

STARION | Hybrid · Highlight Electric Stove

Hybrid Electric Stove

Hybrid Electric Stove to Expedite Cooking
※Dedicated containers only at the induction crater

- SE-JB652SFC**
- NEG Glass Top Plate, one of the world's Top 3 glasses
 - CERAMA SPEED far-infrared radiant heating elements, the best heating element of the U.S.
 - Dual burner with expanded crater
 - Induction boost function (2,000W, the highest output in Korea)
 - Slide & direct touch



Induction suitable to dishes requiring quick and high temperature cooking



Highlight suitable to quick cooking for all containers

Highlight Electric Stove

Highlight Electronic Stove
MADE IN GERMANY, German High-end Brand SCHOTT-CERAN Ceramic Glass Top Plate

- SE-HLP63SIA**
- German-made high-end SCHOTT SERAN Glass
 - German-made high-end E.G.O Heating Element
 - Dual burner with expanded crater
 - Slide & direct touch



German-made SCHOTT top plate German-made E.G.O heating element



Slide & Direct Touch

STARION | Highlight · Induction Electric Stove



- Modern & Simple Electric Stove**
SE-JL642TFB
- NEG Glass Top Plate, one of the world's Top 3 glasses
 - CERAMA SPEED far-infrared radiant heating elements, the best heating element of the U.S.
 - Dual burner with expanded crater
 - child-lock feature
 - Automatic Power Shut-off

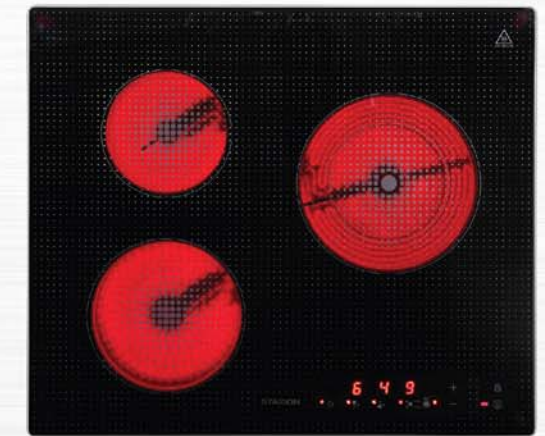

- Highlight Electric Stove**
SE-JC642TKB
- Ceramic glass top plate that is powerful and easy to clean
 - Highlight heating elements emitting healthy far-infrared radiation
 - Dual burner with expanded crater
 - child-lock feature
 - Automatic Power Shut-off



- Portable Extended Crater Highlight**
SE-JL122HCCH
- Highlight electric stove with eco-friendly far-infrared radiation
 - Suitable to places requiring quick-and-easy cookware
 - Portable & Easy-to-store
 - It works with all containers. Easier and more convenient cooking with expanded crater.
 - 8-level temperature control by soft touch and timer feature
 - Safety device for over-heating prevention



- Induction Electric Stove with Highest Output in Korea**
STI2100-WBW
- 15-level burner control
 - Stylish WHITE GLASS HIDDEN LED
 - timer, rapid heating, heat retaining and child-lock functions
 - Overheating-prevention safety device, automatic power shut-off
 - Suitable to places requiring quick-and-easy cookware
 - Portable & Easy-to-store



Healthier, Easier and Safer with STARION Electronic Stove

	Gas Stove	VS	Highlight	VS	Induction Stove
Heating type	Gas combustion		Heat transfer from heating element		Magnetic induction
Heating rate	Low		Fair		High
Container restriction	None		None		Restricted
Burn hazard	High		Fair		Low
Energy efficiency	Low		Fair		High

Time and energy consumed to heat up 1L, 33.8oz of water

Rise Time (25°C ~ 100°C / 77°F ~ 212°F)



Results from in-house tests

Distinctive Strength of Electric Stove / No gas explosion! No toxic gas! Easy-to-Use!

Less burdens on electricity bill but with more satisfaction!

■ Assessment standards for electricity bills
337kwh of Average monthly electricity bill for 4 people per family (Data from the Ministry of Trade, Industry and Energy and Korea Energy Management Corporation, in 2011)

■ Comparative Standards (progressive tax applied)
1 soup, 2 side dishes heated once for each 2L of water heated in 2 craters twice (a total of 6 times of heating)

Payment to use a gas stove + USD 7.6 for additional month (Exchange Rate: USD 1 = 1,125won)

Economic and efficient kitchen

What is the air like in my house when preparing for dinner?

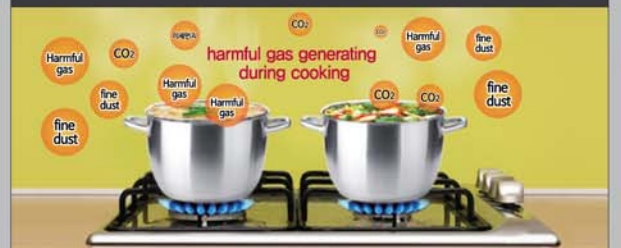

Try an electric stove for healthy air in the kitchen.

Rotary Heater
Legend of Rotary Heater
 Best Fit for Small Businesses
 A single rotary heater is more than enough throughout this winter.

No.1
 16 consecutive years of sales in Korea

**Smart heater that talks
 Simpler & Easier! Technology that only STARION can offer**

43m² 6,500Kcal

43m² SH-R06SCH
 Chic Brown / Evaporative High Pressure Discharge Ignition

- Heating Value: 6,500 Kcal/h
- Tank Capacity: 16.5 l / 558oz
- Fuel Consumption : 0.78(l/h)/26.4(oz/h) during high combustion
- Dimension (WxDxH) : 441x541x700mm/17.4"x21.3"x27.6"
- Weight : 19.5 kg/43 lb
- Power Consumption: 30W (during combustion)

Stronger Durability
 Durable hot air blower that last longer From tiny office to spacious factory A variety of product groups

79.2m² 82.5m² 102m² 139m²

Much stronger! Best Efficiency!

- Emission gas, NOx (nitrogen oxide) improved by 20% through improvement of burner performance (limited to SH-F09SH model)
- Heating rate and fuel efficiency improved by 20% through application of BAFFLE (limited to SH-F09SH model)
- White LED Display, highly-visible under all working environments, applied to remote controls of all models

20% Improved (limited to SH-F09SH model)
 Fuel efficiency, harmful gas

82.5m² 9,000Kcal

Remote Control

82.5m² SH-F09SIH
 Warm Grey / Remote Control

- Heating Value: 9,000 Kcal/h
- Tank Capacity: 30 l / 1,014oz
- Fuel Consumption : 1.0(l/h)/33.8(oz/h) during high combustion
- Dimension (WxDxH) : 950x350x960mm/37.4"x13.8"x37.8"
- Weight : 46 kg/101 lb
- Power Consumption: 70W (during combustion)

Only Korea

43m² SH-R06SCH
 Chic Brown / Evaporative High Pressure Discharge Ignition

- Heating Value: 6,500 Kcal/h
- Tank Capacity: 16.5 l / 558oz
- Fuel Consumption : 0.78(l/h)/26.4(oz/h) during high combustion
- Dimension (WxDxH) : 441x541x700mm/17.4"x21.3"x27.6"
- Weight : 19.5 kg/43 lb
- Power Consumption: 30W (during combustion)

43m² SH-R06SBH
 La Mer Blue / Evaporative High Pressure Discharge Ignition

- Heating Value: 6,500 Kcal/h
- Tank Capacity: 16.5 l / 558oz
- Fuel Consumption : 0.78(l/h)/26.4(oz/h) during high combustion
- Dimension (WxDxH) : 441x541x700mm/17.4"x21.3"x27.6"
- Weight : 19.5 kg/43 lb
- Power Consumption: 30W (during combustion)

56m² SH-R08SCH
 Chic Brown / Evaporative High Pressure Discharge Ignition

- Heating Value: 6,500 Kcal/h
- Tank Capacity: 16.5 l / 558oz
- Fuel Consumption : 0.97(l/h)/32.8(oz/h) during high combustion
- Dimension (WxDxH) : 441x541x700mm/17.4"x21.3"x27.6"
- Weight : 19.5 kg/43 lb
- Power Consumption: 30W (during combustion)

56m² SH-R08SBH
 La Mer Blue / Rotary Atomizing High Pressure Discharge Ignition

- Heating Value: 8,000 Kcal/h
- Tank Capacity: 16.5 l / 558oz
- Fuel Consumption : 0.97(l/h)/32.8(oz/h) during high combustion
- Dimension (WxDxH) : 441x541x700mm/17.4"x21.3"x27.6"
- Weight : 19.5 kg/43 lb
- Power Consumption: 35W (during combustion)

79m² SH-R11SCH
 Chic Brown / Rotary Atomizing High Pressure Discharge Ignition

- Heating Value: 11,500 Kcal/h
- Tank Capacity: 20 l / 676oz
- Fuel Consumption : 1.35(l/h)/45.6(oz/h) during high combustion
- Dimension (WxDxH) : 473x574x785mm/18.6"x22.6"x30.9"
- Weight : 23.5 kg/52 lb
- Power Consumption: 32W (during combustion)

102m² SH-R15SCH
 Chic Brown / Rotary Atomizing High Pressure Discharge Ignition

- Heating Value: 15,000 Kcal/h
- Tank Capacity: 20 l / 676oz
- Fuel Consumption : 1.8(l/h)/60.9(oz/h) during high combustion
- Dimension (WxDxH) : 473x574x785mm/18.6"x22.6"x30.9"
- Weight : 23.5 kg/52 lb
- Power Consumption: 34W (during combustion)

20% Improved (limited to SH-F09SH model)

82.5m² SH-F09SIH
 Warm Grey / Remote Control

- Heating Value: 9,000 Kcal/h
- Tank Capacity: 30 l / 1,014oz
- Fuel Consumption : 1.0(l/h)/33.8(oz/h) during high combustion
- Dimension (WxDxH) : 950x350x960mm/37.4"x13.8"x37.8"
- Weight : 46 kg/101 lb
- Power Consumption: 70W (during combustion)

Compact Size

79.2m² SH-F09CIH
 Warm Grey / Remote Control

- Heating Value: 9,000 Kcal/h
- Tank Capacity: 25 l / 845oz
- Fuel Consumption : 0.97(l/h)/32.8(oz/h) during high combustion
- Dimension (WxDxH) : 800x350x960mm/33.5"x13.8"x37.8"
- Weight : 45 kg/99 lb
- Power Consumption: 70W (during combustion)

Compact Size

79.2m² SH-F09CRH
 Wine Red / Remote Control

- Heating Value: 9,000 Kcal/h
- Tank Capacity: 25 l / 845oz
- Fuel Consumption : 0.97(l/h)/32.8(oz/h) during high combustion
- Dimension (WxDxH) : 800x350x960mm/33.5"x13.8"x37.8"
- Weight : 45 kg/99 lb
- Power Consumption: 70W (during combustion)

NEW

102m² SH-F11SSH
 Silver Pearl / Remote Control

- Heating Value: 11,000 Kcal/h
- Tank Capacity: 30 l / 1,014oz
- Fuel Consumption : 1.2(l/h)/40.6(oz/h) during high combustion
- Dimension (WxDxH) : 950x390x1,070mm/37.4"x15.4"x42.1"
- Weight : 51.5 kg/114 lb
- Power Consumption: 70W (during combustion)

139m² SH-F15SIH
 Warm Grey / Remote Control

- Heating Value: 15,000 Kcal/h
- Tank Capacity: 30 l / 1,014oz
- Fuel Consumption : 1.75(l/h)/59.2(oz/h) during high combustion
- Dimension (WxDxH) : 1,150x350x1,280mm/45.3"x13.8"x50.4"
- Weight : 64 kg/141 lb
- Power Consumption: 70W (during combustion)

Safer than ever! 12 safety features, the most ever in Korea (applicable to all models)

- Preventive device for excessive room temperature rise
- Ignition safety device
- Automatic sprinkler system for 1-3 hours
- Low fuel detection device
- Motor/burner protective device
- Safety device for power outage
- Combustion control system
- Ignition-explosion prevention device
- Motor protection device
- Impact fire extinguisher
- Overheating Prevention Device
- 3-hour automatic 3 fire extinguisher
- Burner overheating prevention device
- Over-current
- Abnormal combustion control device
- Ignition-explosion prevention device
- Impact fire extinguisher
- Detection device for anomaly in the room temperature sensor

Safer than ever! 11 safety features, the most ever in Korea (applicable to all models)

- Ignition safety device
- Preventive device for excessive room temperature rise
- Incomplete combustion prevention device
- Low fuel detection device
- Safety device for power outage
- Combustion control system
- Ignition-explosion prevention device
- Motor protection device
- Impact fire extinguisher
- Overheating Prevention Device
- 3-hour automatic 3 fire extinguisher

Korea's first-ever far-infrared radiation emission effect

Counter action, wet-dry action, intellectual action, aging action, resonance action

Display of target temperature, 14-level temperature control system (All other products are featured with 7 levels or less) Automatic heating control / one-touch automatic operation feature

Fuel efficiency improved by 20% through the application of BAFFLE, STARION's own technology
 More efficiency, less burden on household expenditures

High efficiency heating concept of hot air blower

Applicable use of far-infrared radiant hot air blower

Temperature distribution of conventional hot air blower vs. Temperature distribution of far-infrared radiant hot air blower

This product is suitable to places where heating efficiency is low with conventional heaters because of wide area and high ceiling.

For indoor use: Lobby (hotel, bank, school, building), restaurant, rest area, hospital, library, training center, office, retail shop, church, gas station, and drug store.

For outdoor use: Open spaces such as golf course, theme park, outdoor events, outdoor studio, auto repair shop, airport, terminal, construction site and ski slope.

A company specialized in comprehensive home appliances

Quality Control

The company manufactures products close to and in direct contact with people based on technologies manufacturing the most reliable refrigerators with the highest quality in the industry.

Stay close to daily life for 50 years

STARION is a professional brand dedicated to developing core technologies for home electronics, precision manufacturing, information & communication and automotive parts in order to bring happiness to daily lives throughout all facets of life.

Customer Satisfaction

STARION is determined to ensure customer satisfaction at all times for the sake of customers' happiness as it always has by staying close to daily lives of all customers.



Our Heritage



1960'S

1965
·Sung Chull MFG established



1970'S

1976
·Refrigerator evaporator manufactured
·Development of OEM products (gasoline stove, electric stove)



1979

·Steering wheel for automobile manufacture



1980'S

1985
·Honored with the Order of Steel Tower Industry
·Changwon Factory of Sung Chull MFG completed
·KS for gas stove & gas range acquired



1986

·Wonwoo Precision Co., Ltd. established (manufacturing components of LCD & ODD)



1990'S

1991
·Kiwon Co., Ltd. established (manufacturing evaporator for refrigerator)



1992
Hana Co., Ltd. established (manufacturing wire condenser for refrigerator)

1993

ILWOO Precision Co. Ltd established (manufacturing vehicle wheel)

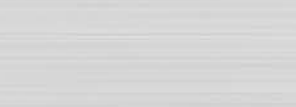

1996

·Local corporation established in Indonesia



1999
·OEM of commercial refrigerator

·Local corporation established in the U.S. and Mexico

2000'S

2000

·Local corporation established in China
·Heater launched



2001

·Local corporation established in India
·Electric fan under original brand launched
·Honored with 20 million Export Towers



2002
·Local corporation established in Monterrey, Mexico
·STARION Technology Institute established



2003

·Local corporation established in Huizhou, China
·Local corporation established in Nanjing, China



2005

·Local corporation established in Taizhou, China

2006

·Local corporation established in Poland

2009

·Reynosa established

2014

·Airo Cook electric oven launched



2015

·Electric stove launched



2015

·STARION commercial refrigerator launched



·air purifier
·Honored with Red Dot Concept Award
·Steering wheel supplied for Tivoli of SsangYong Motor Tivoli



2016년

·Dishwasher launched

